

G2 Series Industrial Grade Meters

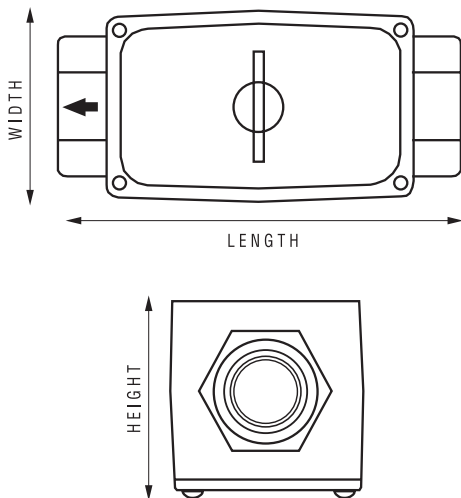

| Model | Length inches (mm) | Height inches (mm) | Width inches (mm) | Model | Length inches (mm) | Height inches (mm) | Width inches (mm) |
|-------|-----------------------|-----------------------|----------------------|-------|-----------------------|-----------------------|----------------------|
| A05 | 4.2 (107) | 1.8 (46) | 2.0 (51) | H20 | 6.3 (160) | 3.2 (81) | 3.3 (84) |
| A07 | 4.3 (109) | 2.0 (51) | 2.0 (51) | P05 | 7.3 (185) | 3.2 (81) | 2.1 (53) |
| A10 | 4.5 (114) | 2.2 (56) | 2.0 (51) | P10 | 8.1 (206) | 3.3 (84) | 2.8 (71) |
| A15 | 5.3 (135) | 2.8 (71) | 2.7 (68) | S05 | 4.2 (107) | 1.8 (46) | 2.0 (51) |
| A20 | 6.3 (160) | 3.2 (81) | 3.3 (84) | S07 | 4.3 (109) | 2.0 (51) | 2.0 (51) |
| B05 | 4.2 (107) | 1.8 (46) | 2.0 (51) | S10 | 4.5 (114) | 2.2 (56) | 2.0 (51) |
| B07 | 4.3 (109) | 2.0 (51) | 2.0 (51) | S15 | 5.3 (135) | 2.8 (71) | 2.7 (68) |
| B10 | 4.5 (114) | 2.2 (56) | 2.0 (51) | S20 | 6.3 (160) | 3.2 (81) | 3.3 (84) |
| B15 | 5.3 (135) | 2.8 (71) | 2.7 (68) | S10F | 6.75 (171) | 4.25 (108) | 4.25 (108) |
| B20 | 6.3 (160) | 3.2 (81) | 3.3 (84) | S15F | 8.0 (203) | 5.0 (127) | 5.0 (127) |
| C05 | 7.3 (185) | 3.2 (81) | 2.1 (53) | S20F | 9.50 (241) | 6.0 (152) | 6.0 (152) |
| C10 | 8.1 (206) | 3.3 (84) | 2.8 (71) | S05T | 5.0 (127) | 2.0 (51) | 1.8 (46) |
| H05 | 4.2 (107) | 1.8 (46) | 2.0 (51) | S07T | 5.0 (127) | 2.0 (51) | 2.0 (51) |
| H07 | 4.3 (109) | 2.0 (51) | 2.0 (51) | S10T | 5.5 (140) | 2.0 (51) | 2.2 (56) |
| H10 | 4.5 (114) | 2.2 (56) | 2.0 (51) | S15T | 6.5 (165) | 2.7 (68) | 2.8 (71) |
| H15 | 5.3 (135) | 2.8 (71) | 2.7 (68) | S20T | 7.0 (178) | 3.3 (84) | 3.2 (81) |

NOTE: 09 Display adds 0.67 in. (17 mm) to height.

NOTE: Dimensions are for reference only and may vary by model.